

System 179 Commercial Lifter (CL)

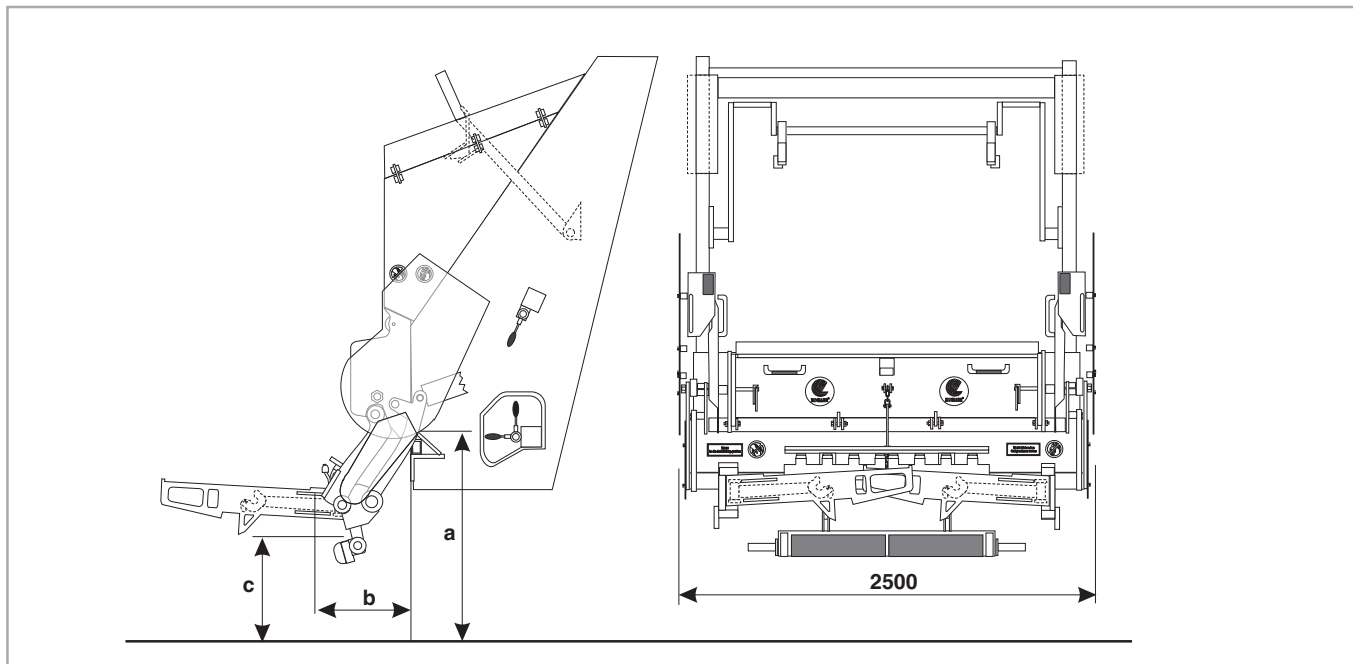

ZOELLER-System 179 – Integrated bulk-container lifter with pocket receiver (TA) unsplit lifting comb + DIN-folding arms



Legend

- * Cycle time (without dwell time) depends on installation height, container size and oil viscosity.
- ** Lifting and tipping capacities refer to max. use of nominal container capacity with a refuse density acc. to standard.
- *** Data relating to working area w/o container.

¹⁾ Swivel container support

²⁾ Guide flap folding down

© by ZÖLLER-KIPPER GmbH • As of: 11/2018.
 Technical data subject to modification without prior notice.

Container types	Container	Container	Container	Container	Bulk refuse cont. TA	Bulk refuse cont. TA
Specification in accordance w. model list	80/120l	140/240/340l	500-1200l	770-1300l	2,5-5 m ³	2,5-5 m ³
Special containers upon request	EN 840-1	EN 840-1	EN 840-2	EN 840-3	EN12574 (Flat lid.)	EN12574 (Dome lid)
Lifter dimensions in mm						
a Setting height	1050 ⁺⁸⁰	1050 ⁺⁸⁰	1050 ⁺⁸⁰	1050 ⁺⁸⁰	1050 ⁺⁸⁰	1050 ⁺⁸⁰
b max. overhang	350	350	350	350	350	350
c Ground clearance ¹⁾	app.260	app.260	app.260	app.260	app.260	app.260
d Rave rail height ²⁾						
Technical data						
Cycle time *	app..10 s	app..10 s	app.10 s	app.10 s	app.20 s	app.20 s
Lifting and tipping capacities **	3500 N	3500 N	3500 N	7000 N	15000 N	15000 N
Noise level ***	72 dB (A)	72 dB (A)	72 dB (A)	72 dB (A)	77 dB (A)	77 dB (A)
Hydraulic flow required	40-50 l/min					
Operating pressure	210 bar					
Operating voltage	24 V					
Weight	app.. 1100 kg					

ZÖLLER-KIPPER GmbH • Hans-Zöller-Straße 50-68 • D-55130 Mainz • Tel. +49(0)6131-887-0 • Fax +49(0)6131-882382 • info@zoeller-kipper.de • www.zoeller-kipper.de

