

# THE NEW REGULATIONS FOR REFUSE COLLECTION VEHICLES

AS OF 11 OCTOBER 2023, THE AMENDED REQUIREMENTS OF DIN EN 1501-1:2021 APPLY.

## SHORT & SNAP

The innovations have a great influence on the execution and functionality of the:

1. STEPS
2. LIFTER OPERATION
3. HANDGRIPS
4. CAMERA SYSTEMS
5. MAXIMUM SPEEDS
6. WORK LIGHTS

This leaflet contains the essential changes and functions.

A detailed description is available in the **standard sheets of DIN EN 1501-1:2021.**

**MORE SAFETY & SMOOTHER VEHICLE OPERATION**

11/2023\_D. All data without guarantee.

## 1. STEPS

With the new regulation of DIN 1501-1, a distinction is made between **THREE STEP POSITIONS:**

**1.** Step folded up, unoccupied and unusable

Forward drive: **POSSIBLE** without restriction

Reverse drive: **POSSIBLE** at maximum speed of 9 km/h

**2.** Step folded down, unoccupied, but usable

Forward drive: **POSSIBLE** without restriction

Reverse drive: **NOT POSSIBLE**

**3.** Step folded down, occupied, i.e. used

Forward drive: **POSSIBLE** at maximum speed of 25 km/h resp. 30 km/h (depending on the mounting position of the steps)

Reverse drive: **NOT POSSIBLE**

**!** Proper operation of the steps and monitoring is checked **EVERY TIME** the body control is started.

### REVERSE DRIVE

There are two options for reverse drive.

1. Basically: The steps must be in **POSITION 1.**
2. Exception: The **OVER-RIDE DEVICE** is triggered.

**ATTENTION:** If the over-ride device is used e.g. in an emergency situation, body, compaction and filling can be used **ONLY AFTER 15 MINUTES.**

### RE-REGULATION DURING BACKWARD MOVEMENT

If the vehicle rolls back (e.g. on a slope) and the step is in position 2 or 3, the driver receives a clear signal in the cab.

**ATTENTION:** If the driver does not brake the vehicle within one second, compaction and filling can be used again **ONLY AFTER 15 MINUTES.**



**!** **IMPORTANT**  
In both cases, the 15-minute compulsory break does not start until the vehicle

- is stationary and
- the ignition is switched on.

It is possible to move the vehicle, but the 15-minute compulsory break will then start again.

## 2. LIFTER OPERATION

When the steps are occupied, a signal is given to the lifter via the lifter interface.

**!** With this signal, automatic and semi-automatic operation of the lifter is now no longer possible.

## 3. HAND GRIPS

**New, ergonomic handle position.** The grip distance has been set at 345 mm. This is an optimal position that is oriented towards the human anatomy and provides a secure grip.

## 4. CAMERA SYSTEMS

Redefinition of the areas to be covered by the CMS (camera monitor system).

ZOELLER refuse collection vehicles basically meet the new requirements. Additional cameras are required in conjunction with system filings to meet the requirements.

The camera images are shown in the display of the **ZOELLER-CONTROL-SYSTEMS (ZCS)** according to the new standard. The extremely compact design of the cameras does **NOT** affect their field of view and image quality.

## 5. MAXIMUM SPEEDS

**!** If essential vehicle components are not in transport position or are in an unsafe condition, the maximum speed is automatically limited to 9 km/h.

**EXAMPLE:** The rear section is not closed and locked or an attachment (e.g. crane, lifter) is not in transport position.

**IMPORTANT:** The return speed is always limited to 9 km/h, regardless of the position or presence of steps.



## 6. WORK LIGHTS

More safety and comfort for the operators of the refuse collection vehicle and less distraction for other road users: For this purpose, work areas and other areas to be illuminated have been redefined. Thanks to uniform, bright and glare-free luminaires, previous worklights can be dispensed with. **In many cases, the previous worklights do not meet the new requirements!**

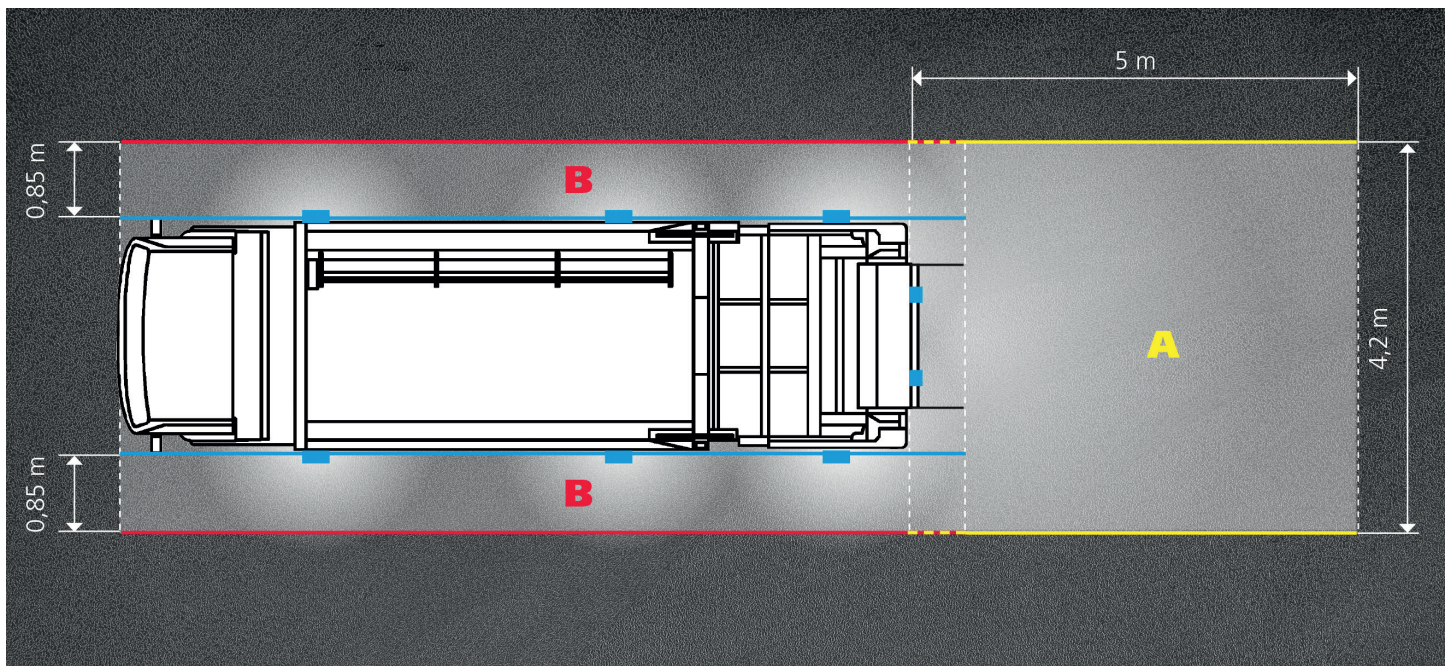

### KONTAKT

ZÖLLER-KIPPER GmbH  
Hans-Zöller-Straße 50-68 | 55130 Mainz  
T +49 6131 887-0 | F +49 6131 882382  
www.zoeller-kipper.de