

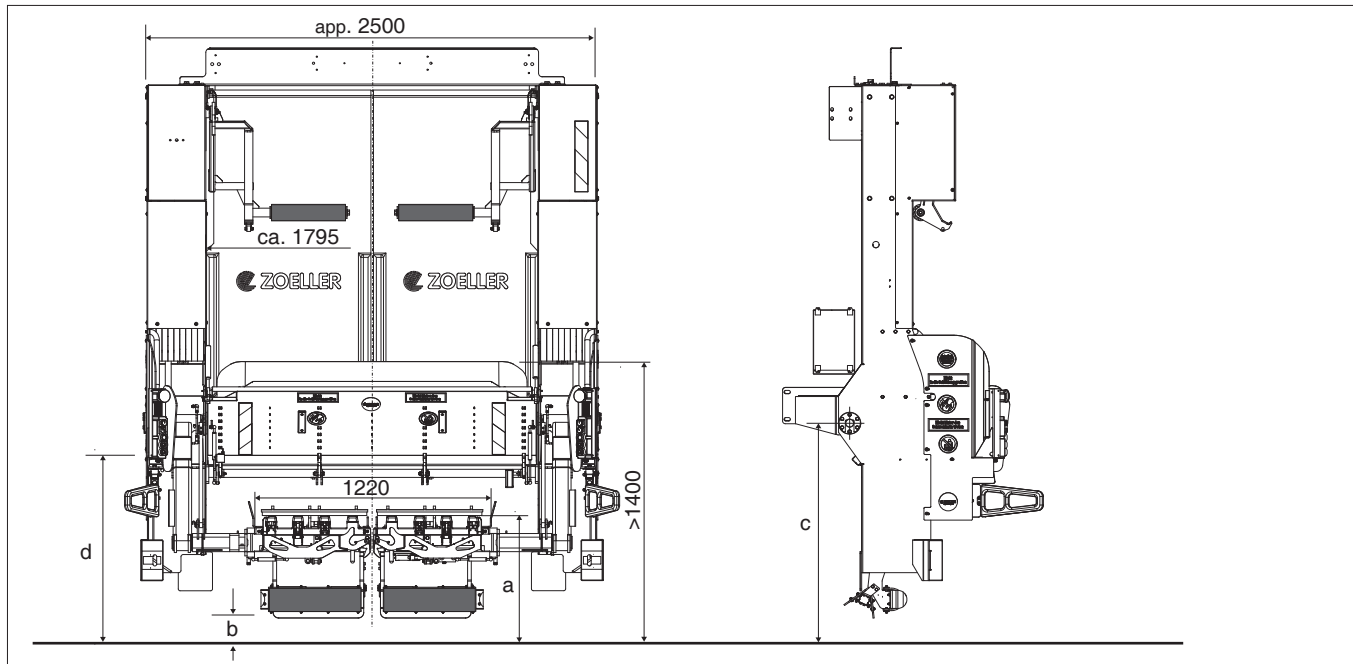

ZOELLER-GAMMA-2349 – The integrated automatic lifter



Legend

- * Cycle time (incl. Pickup time, deposit time, dwell time) depends on installation height, container size and oil viscosity.
- ** Lifting and tipping capacities refer to max. use of nominal container capacity with a refuse density acc. to standard, depending on the centre of gravity
- *** Data relating to working area w/o container.

- 1) Container support pivoting
- 2) Guide flap lowered - chassis related
- 3) Container range is model related
- 4) Changed mounting dimensions for use in Benelux countries

© by ZÖLLER-KIPPER GmbH • As of: 9/2022.
Technical data subject to modification without prior notice.

Container types ³⁾	Cont.	Cont.	Cont.	Cont.	Cont. ⁴⁾
Specification in acc. with model list	80/120 I	140/240/340 I	500-1200 I	770-1300 I	140/240/340 I
Special containers on request	EN 840-1	EN 840-1	EN 840-2	EN 840-3	EN 840-1
Lifter dimensions in mm					
a Setting height	820	900	950-1150	1150	860
b Ground clearance ¹⁾	330	410	630	630	370
c Installation height	1330	1330	1330	1330	1374-1380
d Loading height ²⁾	1135	1135	1135	1135	1175
Technical data					
Cycle time *	app. 9 s	app. 9 s	app. 12 s	app. 12 s	app. 9 s
Lifting and tipping capacities **	3500 N	3500 N	7000 N	7000 N	3500 N
Noise level *** approx.	72 dB (A)	72 dB (A)	72 dB (A)	72 dB (A)	72 dB (A)
Hydraulic flow at coupling	40-46 l/min				
Operating pressure	150-190 bar				
Operating voltage	24 V				
Weight	app. 900 kg				

ZÖLLER-KIPPER GmbH • Hans-Zöller-Straße 50-68 • D-55130 Mainz • Tel. +49(0)6131-887-0 • Fax +49(0)6131-882382 • info@zoeller-kipper.de • www.zoeller-kipper.de